

ARKETIPO / DIVANI-EN

# PUNTA ALA

designed by Mauro Lipparini 2022



**STRUCTURE:** zinc-coated metal, epoxy powder coating, colours corten and olive.

**SPRINGING:** zinc-coated, varnished metal slats.

**UPHOLSTERY - STANDARD VERSION:**

**SEAT, BACK AND ARM CUSHION:** high resilient, waterproof, multi-density non-deformable polyurethane foam. Inner cover in breathable and waterproof polyester, which improves protection from water and moisture. Back and arm cushions have a weighted insert to increase stability.

**UPHOLSTERY - DRAINING VERSION:**

**SEAT, BACK AND ARM CUSHION:** open-cell expanded polyurethane DRYFELL S covered with 3D filter lining.

**PILLOW:** polyester fibre covered with waterproof laminated canvas and breathing net to allow water draining.

**BELTS:** beige or grey polypropylene

**SHELF:** structure in zinc-coated metal, epoxy powder coating, colours corten and olive; top in solid iroko wood with water-repellent vegetable oils finish.

**SEAT HEIGHT:** 40 cm

**ARM HEIGHT:** 67 cm

**ATTENTION:** the upholstery cannot be exposed to constant and heavy rains. We suggest using our protective covers made of breathable and waterproof polyester marine canvas, ideal to prevent mould formation. They can be washed with neutral detergent. Please do not fold wet covers and store them only when dry.

Armchair

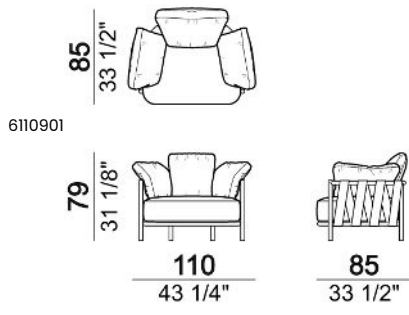

Sofa

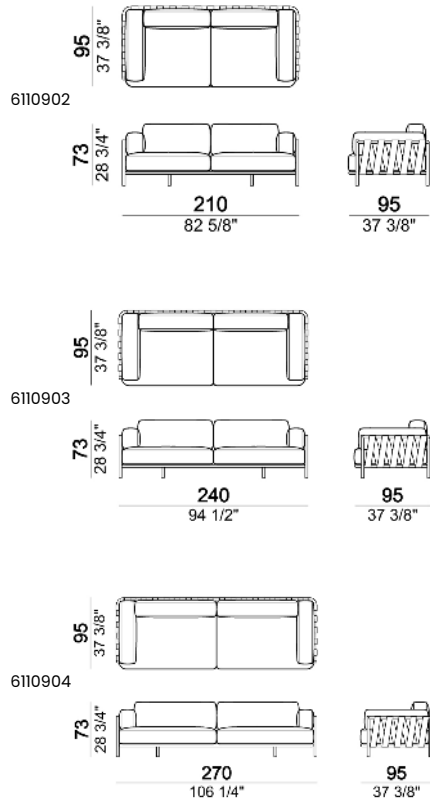

Armcushion

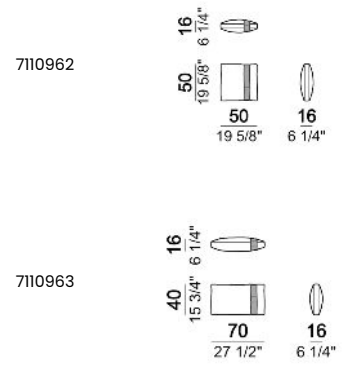

# Shelf

