

ARKETIPO / SENZA-CATEGORIA-2

BACK PACK

designed by Giuseppe Vigano' 2022



STRUCTURE (seats and backs):wood.

SEAT UPHOLSTERY:multi-density expanded polyurethane foam (D30+Memory foam) covered with synthetic lining 230gr.

BACK UPHOLSTERY:multi-density expanded polyurethane foam (D30+D25) covered with synthetic lining 230gr.

BACKREST ROLL UPHOLSTERY:expanded polyurethane covered with coupled synthetic lining 180gr.

BACK CUSHION UPHOLSTERY (7110862): outer side in downproof 100% Gabardine 30/20 cotton cover; filling in goose feathers and polyester fibres.

BACK CUSHION UPHOLSTERY (7110863): outer side in downproof 100% Gabardine 30/20 cotton cover; filling in 100% goose feathers, inner core in expanded polyurethane (T18S).

SEAT HEIGHT:37 cm.

BACK HEIGHT: 66 cm.

FEET: Pouf: plastic, h. 3 cm - Back: metal varnished micaceous brown, h. 1,5 cm.

SMALL TABLE: wood veneered in eucalyptus or zebrano.

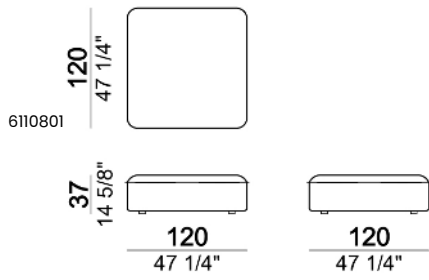
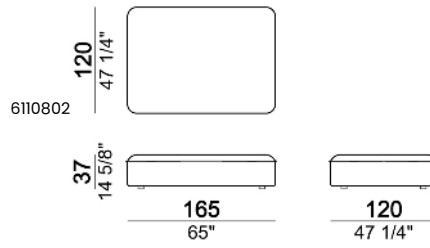
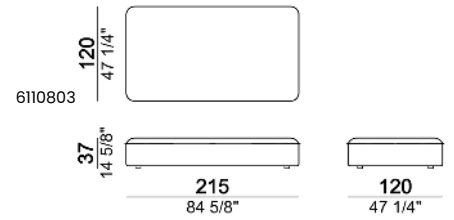
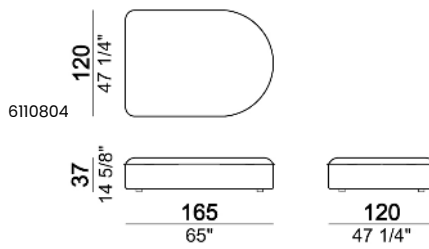
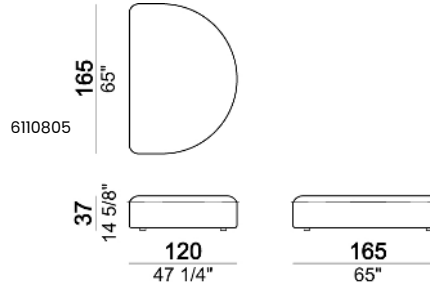
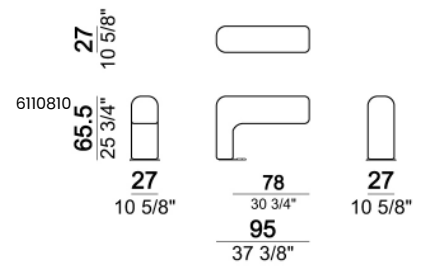
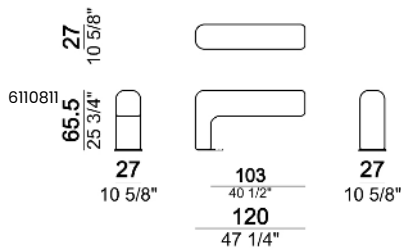
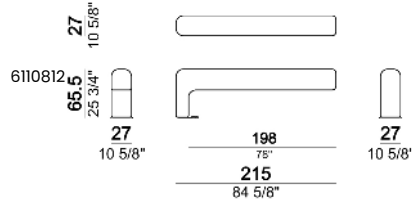
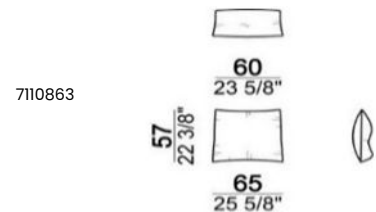
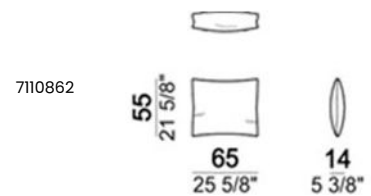
Seat unit A1**Seat unit A2****Seat unit A3****Seat unit B1****Seat unit C1****Back S1****Back S2****Back S3****Back cushion**

Roll for arm or back cushion support

7110865

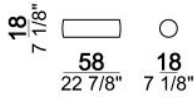

Small table

57108

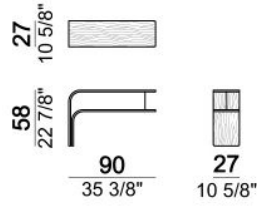

Composition 'A' (seat unit A3 + no.2 backs S2 + no.2 back cushions + small table).

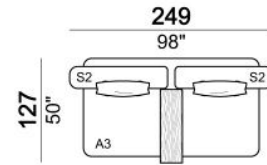

Composition 'B' (seat unit B1 + seat unit C1 + no.2 backs S2 + roll + no. 2 back cushions + small table).

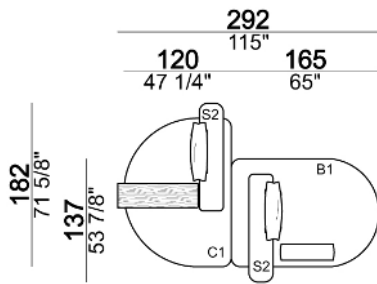

Composition 'C' (seat unit A2 + seat unit B1 + seat unit C1 + no.2 backs S2 + no.1 back S1 + roll + no.3 back cushions + small table).

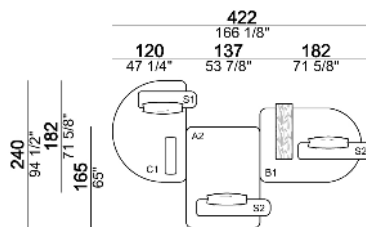

Composition 'D' (seat unit A2 + seat unit B1 + no.2 backs S2 + no.2 back cushions + roll).

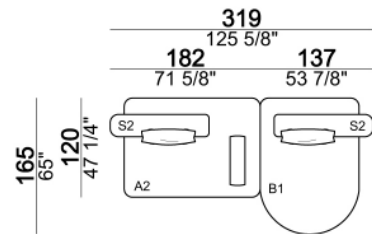

Composition 'E' (seat unit A3 + no.1 back S3 + no.2 back cushions + roll).

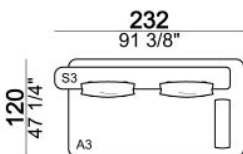

Composition 'F' (no. 2 seat units C1 + no.1 back S2 + no.2 back cushions + roll).

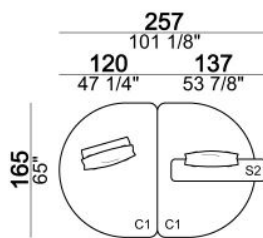

Composition 'G' (seat unit A3 + seat unit B1 + seat unit C1 + no.2 backs S2 + no.1 back S3 + no.3 back cushions + no. 2 rolls + small table).

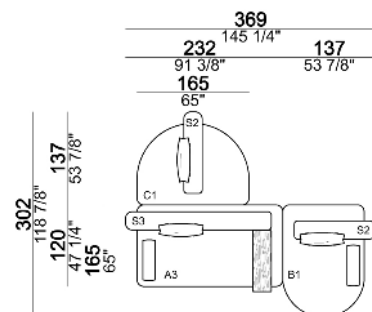

Composition 'H' (no.2 seat units A2 + no.2 seat units B1 + no.2 backs S2 +no.1 back S3 + no.5 back cushions + roll).

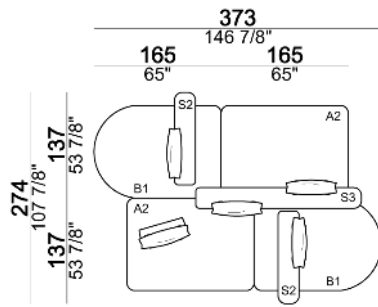

Composition 'L' (seat unit A3 + seat unit B1 + 1 back S2 + 1 back S3 + 2 back cushions 7110862 + 1 back cushion 7110863 + 1 roll + small table).

